

CURVE ASME B16.9 SHORT RADIUS (R = 1 D)
SHORT RADIUS (R = 1 D) ASME B16.9 ELBOWS

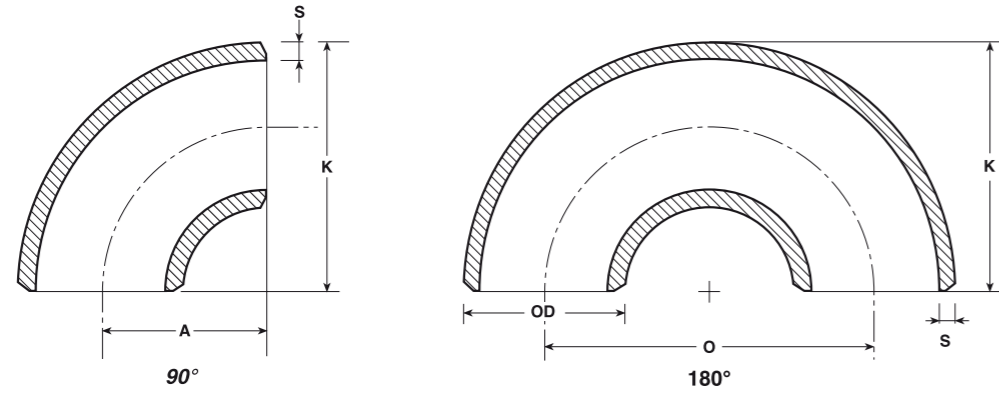

| A | O | K | Ø-dia. | OD | S = SCHEDULE | | | | |
|--------|--------|--------|--------|--------|--------------|---------|---------|---------|---------|
| | | | | | SCH. STD | SCH. XS | SCH. 10 | SCH. 20 | SCH. 30 |
| 25,4 | 50,6 | 41,3 | 1" | 33,4 | 3,38 | 4,55 | — | — | — |
| 31,8 | 63,5 | 52,4 | 1¼" | 42,2 | 3,56 | 4,85 | — | — | — |
| 38,1 | 76,2 | 61,9 | 1½" | 48,3 | 3,68 | 5,08 | — | — | — |
| 50,8 | 101,6 | 81,0 | 2" | 60,3 | 3,91 | 5,54 | — | — | — |
| 63,5 | 127,0 | 100,0 | 2½" | 73,0 | 5,16 | 7,01 | — | — | — |
| 76,2 | 152,4 | 120,6 | 3" | 88,9 | 5,49 | 7,62 | — | — | — |
| 88,9 | 177,8 | 139,7 | 3½" | 101,6 | 5,74 | 8,08 | — | — | — |
| 101,6 | 203,2 | 158,8 | 4" | 114,3 | 6,02 | 8,56 | — | — | — |
| 127,0 | 254,0 | 196,8 | 5" | 141,3 | 6,55 | 9,52 | — | — | — |
| 152,4 | 304,8 | 235,5 | 6" | 168,3 | 7,11 | 10,97 | — | — | — |
| 203,2 | 406,4 | 312,7 | 8" | 219,1 | 8,18 | 12,70 | — | 6,35 | 7,04 |
| 254,0 | 508,0 | 390,5 | 10" | 273,0 | 9,27 | 12,70 | — | 6,35 | 7,80 |
| 304,8 | 609,6 | 466,7 | 12" | 323,8 | 9,52 | 12,70 | — | 6,35 | 8,38 |
| 355,6 | 711,2 | 533,4 | 14" | 355,6 | 9,52 | 12,70 | 6,35 | 7,92 | 9,52 |
| 406,4 | 812,8 | 609,6 | 16" | 406,4 | 9,52 | 12,70 | 6,35 | 7,92 | 9,52 |
| 457,2 | 914,4 | 685,8 | 18" | 457,2 | 9,52 | 12,70 | 6,35 | 7,92 | 11,12 |
| 508,0 | 1016,0 | 762,0 | 20" | 508,0 | 9,52 | 12,70 | 6,35 | 9,52 | 12,70 |
| 558,8 | 1117,6 | 838,2 | 22" | 558,8 | 9,52 | 12,70 | 6,35 | 9,52 | 12,70 |
| 609,6 | 1219,0 | 914,0 | 24" | 609,6 | 9,52 | 12,70 | 6,35 | 9,52 | 14,25 |
| 660,4 | — | 990,6 | 26" | 660,4 | 9,52 | 12,70 | 7,92 | 12,70 | — |
| 711,2 | — | 1066,8 | 28" | 711,2 | 9,52 | 12,70 | 7,92 | 12,70 | 15,88 |
| 762,0 | — | 1143,0 | 30" | 762,0 | 9,52 | 12,70 | 7,92 | 12,70 | 15,88 |
| 812,8 | — | 1219,2 | 32" | 812,8 | 9,52 | 12,70 | 7,92 | 12,70 | 15,88 |
| 863,8 | — | 1295,4 | 34" | 863,6 | 9,52 | 12,70 | 7,92 | 12,70 | 15,88 |
| 914,4 | — | 1371,6 | 36" | 914,4 | 9,52 | 12,70 | 7,92 | 12,70 | 15,88 |
| 1016,0 | — | 1524 | 40" | 1016,0 | 9,52 | 12,70 | — | — | — |
| 1066,8 | — | 1600 | 42" | 1066,8 | 9,52 | 12,70 | — | — | — |
| 1168,4 | — | 1753 | 46" | 1168,4 | 9,52 | 12,70 | — | — | — |
| 1219,2 | — | 1829 | 48" | 1219,2 | 9,52 | 12,70 | — | — | — |

NOTE

- CURVE CON SPESSORI O DIMENSIONAMENTI PARTICOLARI: A RICHIESTA

Remarks

- Elbows with special thickness and size: on application

CURVE ASME B16.9 SHORT RADIUS (R = 1 D)
SHORT RADIUS (R = 1 D) ASME B16.9 ELBOWS



| S = SCHEDULE | | | | | | | | Ø-dia. |
|--------------|---------|---------|----------|----------|----------|----------|----------|--------|
| SCH. 40 | SCH. 60 | SCH. 80 | SCH. 100 | SCH. 120 | SCH. 140 | SCH. 160 | SCH. XXS | |
| 3,38 | — | 4,55 | — | — | — | 6,35 | 9,09 | 1" |
| 3,56 | — | 4,85 | — | — | — | 6,35 | 9,70 | 1¼" |
| 3,68 | — | 5,08 | — | — | — | 7,14 | 10,16 | 1½" |
| 3,91 | — | 5,54 | — | — | — | 8,74 | 11,07 | 2" |
| 5,16 | — | 7,01 | — | — | — | 9,52 | 14,02 | 2½" |
| 5,49 | — | 7,62 | — | — | — | 11,12 | 15,24 | 3" |
| 5,74 | — | 8,08 | — | — | — | — | — | 3½" |
| 6,02 | — | 8,56 | — | 11,12 | — | 13,49 | 17,12 | 4" |
| 6,55 | — | 9,52 | — | 12,70 | — | 15,87 | 19,05 | 5" |
| 7,11 | — | 10,97 | — | 14,27 | — | 18,24 | 21,94 | 6" |
| 8,18 | 10,30 | 12,70 | 15,06 | 18,24 | 20,62 | 23,01 | 22,22 | 8" |
| 9,27 | 12,70 | 15,06 | 18,24 | 21,41 | 25,40 | 28,57 | 25,40 | 10" |
| 10,31 | 14,30 | 17,45 | 21,41 | 25,40 | 28,57 | 33,32 | 25,40 | 12" |
| 11,12 | 15,10 | 19,05 | 23,80 | 27,76 | 31,75 | 35,71 | — | 14" |
| 12,70 | 16,70 | 21,41 | 26,19 | 30,94 | 36,52 | 40,46 | — | 16" |
| 14,27 | 19,05 | 23,80 | 29,36 | 34,92 | 39,67 | 45,24 | — | 18" |
| 15,06 | 20,60 | 26,19 | 32,54 | 38,10 | 44,45 | 49,99 | — | 20" |
| — | — | — | — | — | — | — | — | 22" |
| 17,45 | 24,60 | 30,94 | 38,89 | 46,02 | 52,37 | 59,51 | — | 24" |
| 17,45 | — | — | — | — | — | — | — | 26" |
| 17,45 | — | — | — | — | — | — | — | 28" |
| 17,45 | — | — | — | — | — | — | — | 30" |
| 17,45 | — | — | — | — | — | — | — | 32" |
| 17,45 | — | — | — | — | — | — | — | 34" |
| 19,05 | — | — | — | — | — | — | — | 36" |
| — | — | — | — | — | — | — | — | 40" |
| — | — | — | — | — | — | — | — | 42" |
| — | — | — | — | — | — | — | — | 46" |
| — | — | — | — | — | — | — | — | 48" |

NOTE

- CURVE CON SPESSORI O DIMENSIONAMENTI PARTICOLARI: A RICHIESTA

Remarks

- Elbows with special thickness and size: on application