

CURVE EN/DIN/ISO R = 1,5 D
EN/DIN/ISO BENDS R = 1,5 D

ISO 3419 - 1981 3D | DIN2605-1 TYPE 3 ST35.8 - ST37.0 | EN 10253-1 3D S235 | EN 10253-2 3D P235GH - P265GH

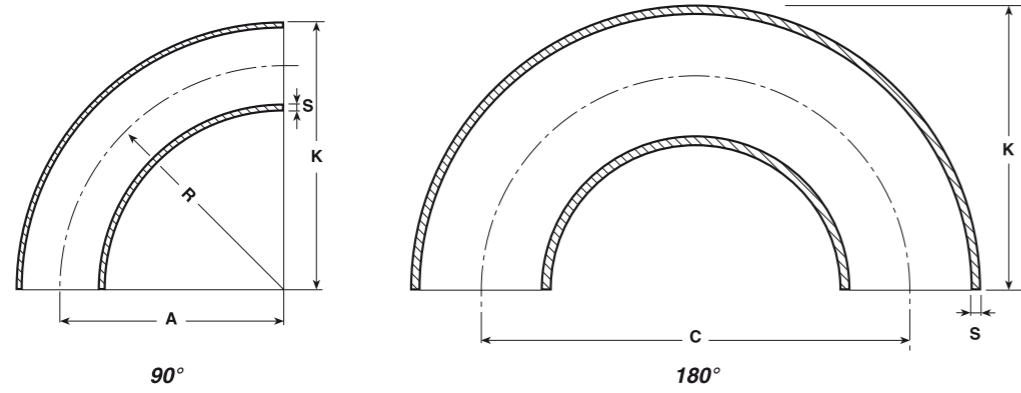

CURVE EN/DIN/ISO R = 1,5 D
EN/DIN/ISO BENDS R = 1,5 D



Ø-dia.	Senza saldatura S	Saldato S	R	A-90°	K	C-180°	TOLLERANZE Tolerances	
							90°	180°
21,3	2,0	—	27,5	27,5	38,0	55,0	± 2,5	± 5,0
26,9	2,3	—	28,5	28,5	42,0	57,0		
33,7	2,6	—	38,0	38,0	55,0	76,0		
38,0	2,6	—	45,0	45,0	64,0	90,0		
42,4	2,6	—	47,5	47,5	69,0	95,0		
44,5	2,6	—	51,0	51,0	73,5	102,0		
48,3	2,6	—	57,0	57,0	82,0	114,0		
51,0	2,6	—	64,0	64,0	89,5	128,0		
57,0	2,9	—	72,0	72,0	100,5	144,0		
60,3	2,9	—	76,1	76,1	106,0	152,2		
70,0	2,9	—	92,0	92,0	127,0	184,0		
76,1	2,9	—	95,0	95,0	133,0	190,0		
82,5	3,2	—	107,5	107,5	149,0	215,0		
88,9	3,2	—	114,3	114,3	159,0	228,6		
101,6	3,6	—	133,5	133,5	184,0	267,0		
108,0	3,6	—	142,5	142,5	196,0	285,0		
114,3	3,6	—	152,5	152,5	210,0	305,0		
133,0	4,0	—	181,0	181,0	247,0	362,0		
139,7	4,0	—	190,5	190,5	260,0	381,0		
159,0	4,5	—	216,0	216,0	295,0	432,0		
168,3	4,5	—	228,6	228,6	313,0	457,2		
193,7	5,4	—	270,0	270,0	367,0	540,0		
219,1	5,9	4,5	305,0	305,0	415,0	610,0		
244,5	6,3	5,6	340,0	340,0	462,5	680,0		
273,0	6,3	5,6	381,0	381,0	517,0	762,0		
323,9	7,1	6,3	457,2	457,2	619,0	914,0		

NOTE

- CURVE CON SPESSORI O DIMENSIONAMENTI PARTICOLARI: A RICHIESTA
- CURVE CON TRATTO DIRITTO, CON SPESSORI O DIMENSIONAMENTI PARTICOLARI: A RICHIESTA

Remarks

- Elbows with special thickness and size: on application
- Elbows with straight-line, special thickness and size: on application

Ø-dia.	Senza Saldatura S	Saldato S	R	A-90°	K	C-180°	TOLLERANZE Tolerances	
							90°	180°
355,6	8,0	6,3	534,0	534,0	711,0	1068,0	± 10,0	± 20,0
368,3	8,0	6,3	534,0	534,0	717,0	1068,0		
406,4	8,8	6,3	609,0	609,0	813,0	1218,0		
419,0	8,8	6,3	609,0	609,0	819,0	1218,0		
457,2	10,0	6,3	686,0	686,0	915,0	1372,0		
508,0	11,5	6,3	762,0	762,0	1016,0	1524,0		
558,0	11,5	6,3	838,0	838,0	1118,0	1676,0	± 70,0	± 100,0
609,6	12,5	6,3	915,0	915,0	1219,0	1830,0		
660,4	12,5	—	990,6	990,6	1320,0	1981,0	± 10,0	± 20,0
711,2	12,5	7,1	1066,8	1066,8	1422,0	2134,0		
762,0	12,5	—	1143,0	1143,0	1524,0	2286,0		
813,0	12,5	8,0	1220,0	1220,0	1626,0	2440,0		
863,6	12,5	—	1295,4	1295,4	1727,0	2590,0		
914,4	12,5	—	1371,6	1371,6	1828,0	2743,0		

NOTE

- CURVE CON SPESSORI O DIMENSIONAMENTI PARTICOLARI: A RICHIESTA
- CURVE CON TRATTO DIRITTO, CON SPESSORI O DIMENSIONAMENTI PARTICOLARI: A RICHIESTA

Remarks

- Elbows with special thickness and size: on application
- Elbows with straight-line, special thickness and size: on application